

بِسْمِ اللَّهِ الرَّحْمَنِ الرَّحِيمِ



پردازش سیگنال دیجیتال

درس ۷

تبدیل Z معکوس

The Inverse z-Transform

کاظم فولادی

دانشکده مهندسی برق و کامپیوتر

دانشگاه تهران

<http://courses.fouladi.ir/dsp>

The Inverse z-Transform

- Formal inverse z-transform is based on a Cauchy integral $x[n] = \frac{1}{2\pi j} \oint_c X(z)z^{n-1} dz$
- Less formal ways sufficient most of the time
 - Inspection method
 - Partial fraction expansion
 - Power series expansion

The Inverse z-Transform by Inspection Method

Inspection Method

- Make use of known z-transform pairs such as

$$a^n u[n] \xleftrightarrow{z} \frac{1}{1 - az^{-1}} \quad |z| > |a|$$

- **Example:** The inverse z-transform of

$$X(z) = \frac{1}{1 - \frac{1}{2}z^{-1}} \quad |z| > \frac{1}{2} \quad \rightarrow \quad x[n] = \left(\frac{1}{2}\right)^n u[n]$$

Inverse z-Transform by Partial Fraction Expansion

- Assume that a given z-transform can be expressed as

$$X(z) = \frac{\sum_{k=0}^M b_k z^{-k}}{\sum_{k=0}^N a_k z^{-k}}$$

- Apply partial fractional expansion

$$X(z) = \sum_{r=0}^{M-N} B_r z^{-r} + \sum_{k=1, k \neq i}^N \frac{A_k}{1 - d_k z^{-1}} + \sum_{m=1}^s \frac{C_m}{(1 - d_i z^{-1})^m}$$

- First term exist only if $M > N$
 - B_r is obtained by long division
- Second term represents all first order poles
- Third term represents an order s pole
 - There will be a similar term for every high-order pole
- Each term can be inverse transformed by inspection

Partial Fractional Expression

$$X(z) = \sum_{r=0}^{M-N} B_r z^{-r} + \sum_{k=1, k \neq i}^N \frac{A_k}{1 - d_k z^{-1}} + \sum_{m=1}^s \frac{C_m}{(1 - d_i z^{-1})^m}$$

- Coefficients are given as

$$A_k = (1 - d_k z^{-1}) X(z) \Big|_{z=d_k}$$

$$C_m = \frac{1}{(s-m)! (-d_i)^{s-m}} \left\{ \frac{d^{s-m}}{dw^{s-m}} \left[(1 - d_i w)^s X(w^{-1}) \right] \right\}_{w=d_i^{-1}}$$

- Easier to understand with examples

Example: 2nd Order z-Transform

$$X(z) = \frac{1}{\left(1 - \frac{1}{4}z^{-1}\right)\left(1 - \frac{1}{2}z^{-1}\right)} \quad \text{ROC: } |z| > \frac{1}{2}$$

- Order of nominator is smaller than denominator (in terms of z^{-1})
- No higher order pole

$$X(z) = \frac{A_1}{\left(1 - \frac{1}{4}z^{-1}\right)} + \frac{A_2}{\left(1 - \frac{1}{2}z^{-1}\right)}$$

$$A_1 = \left(1 - \frac{1}{4}z^{-1}\right)X(z) \Big|_{z=\frac{1}{4}} = \frac{1}{\left(1 - \frac{1}{2}\left(\frac{1}{4}\right)^{-1}\right)} = -1$$

$$A_2 = \left(1 - \frac{1}{2}z^{-1}\right)X(z) \Big|_{z=\frac{1}{2}} = \frac{1}{\left(1 - \frac{1}{4}\left(\frac{1}{2}\right)^{-1}\right)} = 2$$

Example Continued

$$X(z) = \frac{-1}{\left(1 - \frac{1}{4}z^{-1}\right)} + \frac{2}{\left(1 - \frac{1}{2}z^{-1}\right)} \quad |z| > \frac{1}{2}$$

- ROC extends to infinity
 - Indicates right sided sequence

$$x[n] = 2\left(\frac{1}{2}\right)^n u[n] - \left(\frac{1}{4}\right)^n u[n]$$

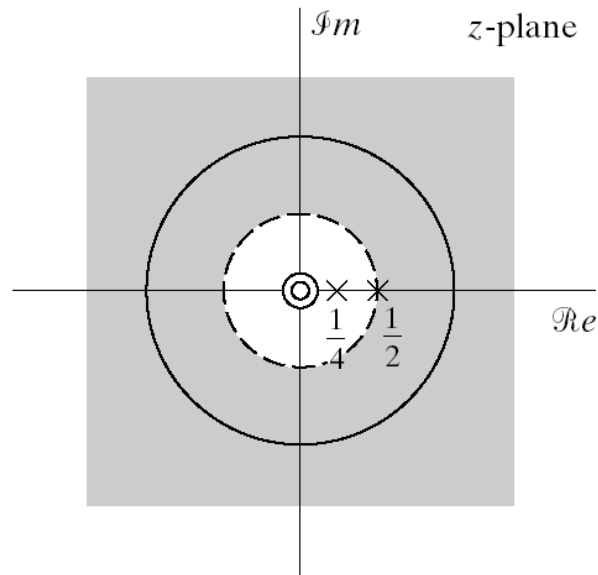

Example #2

$$X(z) = \frac{1 + 2z^{-1} + z^{-2}}{1 - \frac{3}{2}z^{-1} + \frac{1}{2}z^{-2}} = \frac{(1 + z^{-1})^2}{\left(1 - \frac{1}{2}z^{-1}\right)(1 - z^{-1})} \quad |z| > 1$$

- Long division to obtain B_0

$$\begin{array}{r} \frac{1}{2}z^{-2} - \frac{3}{2}z^{-1} + 1 \overline{) z^{-2} + 2z^{-1} + 1} \\ \underline{z^{-2} - 3z^{-1} + 2} \\ 5z^{-1} - 1 \end{array}$$

$$X(z) = 2 + \frac{-1 + 5z^{-1}}{\left(1 - \frac{1}{2}z^{-1}\right)(1 - z^{-1})}$$

$$X(z) = 2 + \frac{A_1}{1 - \frac{1}{2}z^{-1}} + \frac{A_2}{1 - z^{-1}}$$

$$A_1 = \left(1 - \frac{1}{2}z^{-1}\right)X(z) \Big|_{z=\frac{1}{2}} = -9 \quad A_2 = \left(1 - z^{-1}\right)X(z) \Big|_{z=1} = 8$$

Example #2 Continued

$$X(z) = 2 - \frac{9}{1 - \frac{1}{2}z^{-1}} + \frac{8}{1 - z^{-1}} \quad |z| > 1$$

- ROC extends to infinity
 - Indicates right-sided sequence

$$x[n] = 2\delta[n] - 9\left(\frac{1}{2}\right)^n u[n] - 8u[n]$$

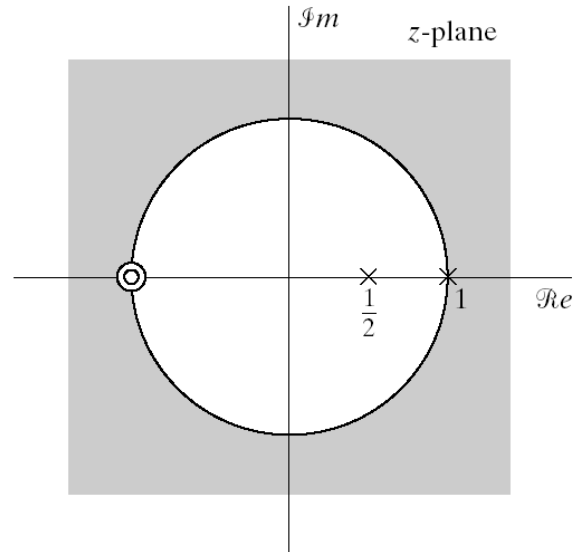

Inverse z-Transform by Power Series Expansion

- The z-transform is power series

$$X(z) = \sum_{n=-\infty}^{\infty} x[n]z^{-n}$$

- In expanded form

$$X(z) = \dots + x[-2]z^2 + x[-1]z^1 + x[0] + x[1]z^{-1} + x[2]z^{-2} + \dots$$

- Z-transforms of this form can generally be inverted easily
- Especially useful for finite-length series
- Example

$$\begin{aligned} X(z) &= z^2 \left(1 - \frac{1}{2}z^{-1}\right) (1 + z^{-1}) (1 - z^{-1}) \\ &= z^2 - \frac{1}{2}z - 1 + \frac{1}{2}z^{-1} \end{aligned} \quad x[n] = \begin{cases} 1 & n = -2 \\ -\frac{1}{2} & n = -1 \\ -1 & n = 0 \\ \frac{1}{2} & n = 1 \\ 0 & n = 2 \end{cases}$$
$$x[n] = \delta[n+2] - \frac{1}{2}\delta[n+1] - \delta[n] + \frac{1}{2}\delta[n-1]$$

z-Transform Properties: Linearity

- Notation

$$x[n] \xleftrightarrow{z} X(z) \quad \text{ROC} = R_x$$

- Linearity

$$ax_1[n] + bx_2[n] \xleftrightarrow{z} aX_1(z) + bX_2(z) \quad \text{ROC} = R_{x_1} \cap R_{x_2}$$

- Note that the ROC of combined sequence may be larger than either ROC
- This would happen if some pole/zero cancellation occurs

- **Example:**

$$x[n] = a^n u[n] - a^n u[n - N]$$

- Both sequences are right-sided
 - Both sequences have a pole $z = a$
 - Both have a ROC defined as $|z| > |a|$
 - In the combined sequence the pole at $z = a$ cancels with a zero at $z = a$
 - The combined ROC is the entire z plane except $z = 0$
- We did make use of this property already, where?

z-Transform Properties: Time Shifting

$$x[n - n_o] \xleftrightarrow{z} z^{-n_o} X(z) \quad \text{ROC} = R_x$$

- Here n_o is an integer
 - If **positive** the sequence is **shifted right**
 - If **negative** the sequence is **shifted left**
- The ROC can change the new term may
 - Add or remove poles at $z = 0$ or $z = \infty$

- **Example**

$$X(z) = z^{-1} \left(\frac{1}{1 - \frac{1}{4} z^{-1}} \right) \quad |z| > \frac{1}{4}$$

$$x[n] = \left(\frac{1}{4} \right)^{n-1} u[n-1]$$

z-Transform Properties: Multiplication by Exponential

$$z_o^n x[n] \xleftrightarrow{z} X(z/z_o) \quad \text{ROC} = |z_o| R_x$$

- ROC is scaled by $|z_o|$
- All pole/zero locations are scaled
- If z_o is a positive real number: z-plane shrinks or expands
- If z_o is a complex number with unit magnitude it rotates
- Example: We know the z-transform pair

$$u[n] \xleftrightarrow{z} \frac{1}{1-z^{-1}} \quad \text{ROC: } |z| > 1$$

- Let's find the z-transform of

$$x[n] = r^n \cos(\omega_o n) u[n] = \frac{1}{2} (re^{j\omega_o})^n u[n] + \frac{1}{2} (re^{-j\omega_o})^n u[n]$$

$$X(z) = \frac{1/2}{1-re^{j\omega_o} z^{-1}} + \frac{1/2}{1-re^{-j\omega_o} z^{-1}} \quad |z| > r$$

z-Transform Properties: Differentiation

$$nx[n] \xleftrightarrow{z} -z \frac{dX(z)}{dz} \quad \text{ROC} = R_x$$

- **Example:** We want the inverse z-transform of

$$X(z) = \log(1 + az^{-1}) \quad |z| > |a|$$

- Let's differentiate to obtain rational expression

$$\frac{dX(z)}{dz} = \frac{-az^{-2}}{1+az^{-1}} \Rightarrow -z \frac{dX(z)}{dz} = az^{-1} \frac{1}{1+az^{-1}}$$

- Making use of z-transform properties and ROC

$$nx[n] = a(-a)^{n-1} u[n-1]$$

$$x[n] = (-1)^{n-1} \frac{a^n}{n} u[n-1]$$

z-Transform Properties: Conjugation

$$x^*[n] \xleftrightarrow{Z} X^*(z^*) \quad \text{ROC} = R_x$$

- Example

$$X(z) = \sum_{n=-\infty}^{\infty} x[n]z^{-n}$$

$$X^*(z) = \left(\sum_{n=-\infty}^{\infty} x[n]z^{-n} \right)^* = \sum_{n=-\infty}^{\infty} x^*[n]z^n$$

$$X^*(z^*) = \sum_{n=-\infty}^{\infty} x^*[n](z^n)^* = \sum_{n=-\infty}^{\infty} x^*[n]z^{-n} = Z\{x^*[n]\}$$

z-Transform Properties: Time Reversal

$$x[-n] \xleftrightarrow{z} X(1/z) \quad \text{ROC} = \frac{1}{R_x}$$

- ROC is inverted
- Example:

$$x[n] = a^{-n}u[-n]$$

- Time reversed version of $a^n u[n]$

$$X(z) = \frac{1}{1-az} = \frac{-a^{-1}z^{-1}}{1-a^{-1}z^{-1}} \quad |z| < |a^{-1}|$$

z-Transform Properties: Convolution

$$x_1[n] * x_2[n] \xrightarrow{z} X_1(z)X_2(z) \quad \text{ROC: } R_{x_1} \cap R_{x_2}$$

- **Convolution in time domain is multiplication in z-domain**

- **Example:** Let's calculate the convolution of

$$x_1[n] = a^n u[n] \quad \text{and} \quad x_2[n] = u[n]$$

$$X_1(z) = \frac{1}{1 - az^{-1}} \quad \text{ROC: } |z| > |a| \quad X_2(z) = \frac{1}{1 - z^{-1}} \quad \text{ROC: } |z| > 1$$

- Multiplications of z-transforms is

$$Y(z) = X_1(z)X_2(z) = \frac{1}{(1 - az^{-1})(1 - z^{-1})}$$

- ROC: if $|a| < 1$ ROC is $|z| > 1$, if $|a| > 1$ ROC is $|z| > |a|$

- Partial fractional expansion of $Y(z)$

$$Y(z) = \frac{1}{1 - a} \left(\frac{1}{1 - z^{-1}} - \frac{1}{1 - az^{-1}} \right) \quad \text{assume ROC: } |z| > 1$$

$$y[n] = \frac{1}{1 - a} (u[n] - a^{n+1}u[n])$$